

**ГОСТ 12459-67. Болты усиленные к  
пазам станочным обработанным.  
Конструкция  
(с Изменениями N 1, 2)**



**ОПМ**

Крепеж и метизы оптом с доставкой по России

[opm.ru](http://opm.ru)

[msk.opm.ru](http://msk.opm.ru)

(812) 335-00-52

(495) 980-60-42

(812) 600-40-71

(495) 258-55-75

(812) 320-28-84

(916) 952-82-57

e-mail: [spb@opm.ru](mailto:spb@opm.ru)

e-mail: [msk@opm.ru](mailto:msk@opm.ru)

1. Конструкция и размеры усиленных болтов к станочным обработанным пазам должны соответствовать чертежу и таблице.

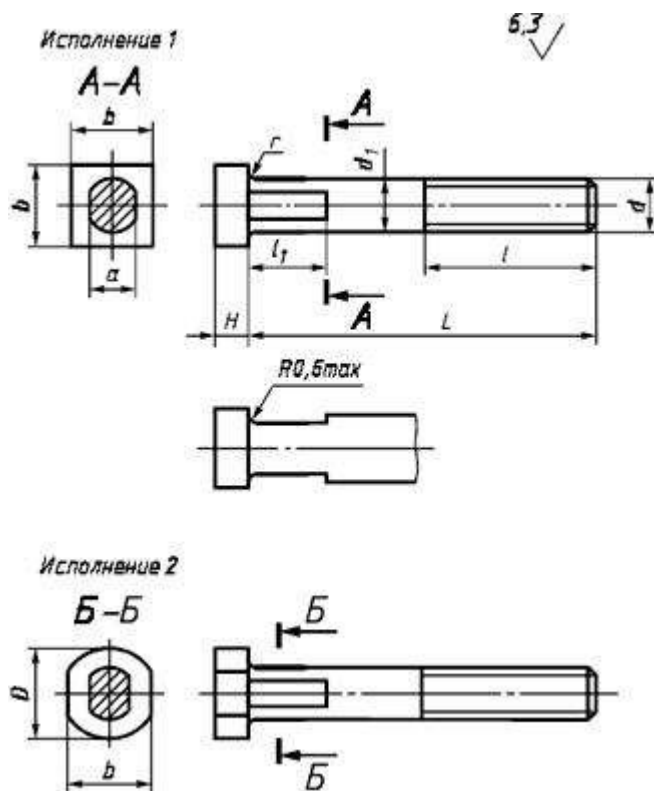

Крепеж и метизы оптом с доставкой по России

[opm.ru](http://opm.ru)

[msk.opm.ru](http://msk.opm.ru)

(812) 335-00-52

(495) 980-60-42

(812) 600-40-71

(495) 258-55-75

(812) 320-28-84

(916) 952-82-57

e-mail: [spb@opm.ru](mailto:spb@opm.ru)

e-mail: [msk@opm.ru](mailto:msk@opm.ru)

Размеры в мм

Обозначения болтов	Применяемость	Исполнение	Ширина станочного паза	d	L	d1	a (поле допуска b12)	b	D	H	l	l1	r	Масса, кг							
7002-2301		1	14	M16	80	16	14	22	-	8,5	40	20	1,0	0,150							
2302		2			-				0,151												
2303		1			90				-					0,164							
2304		2			-				0,165												
2305		1			-				0,179												
2306		2			100				-					0,180							
2307		1			-				0,195												
2308		2			-				0,196												
2309		1			125				-					0,216							
2310		2			-				0,217												
2311		1			140				-					0,240							
2312		2			-				0,240												
2313		1			160				-		0,272										
2314		2			-				0,272												
2315		1			180				-		0,299										
2316		2			-				0,301												
2317		1			200				-		0,331										
2318		2			-				0,331												
2319		1			220				-		0,363										
2320		2			-				0,363												
2321		1			250				-		0,410										
2322		2			-				0,410												
2323		1			280				-		0,457										
2324		2			-				0,457												
2325		1	18	M20	100	20	18	28	-	11,5	50	28	0,292								
2326		2			-				0,292												
2327		1			110				-				0,318								
2328		2			-				0,317												
2329		1			125				-				0,348								
2330		2			-				0,348												
2331		1			140				-				0,386								
2332		2			-				0,384												
2333		1			160				-				0,434								
2334		2			-				0,433												
2335		1			180				-				0,477								
2336		2			-				0,475												
2337		1			200				-		0,526										
2338		2			-				0,525												
2339		1			220				-		0,575										
2340		2			-				0,574												
2341		1			250				-		0,640										
2342		2			-				0,639												
2343		1			280				-		0,714										
2344		2			-				0,713												
2345		1			320				-		0,792										
2346		2			-				0,791												
2347		1			360				-		0,911										
2348		2			-				0,911												
2349		1			400				-		1,010										
2350		2			-				1,009												
2351		1			22				M24		125		24	22	34	-	15,0	80	32	1,6	0,535
2352		2									-					0,543					
2353		1									140					-					0,588
2354		2									-					0,596					
2355		1									160					-					0,659
2356		2	-	0,667																	
2357		1	180	-		0,716															
2358		2	-	0,724																	
2359		1	200	-		0,787															
2360		2	-	0,795																	
2361		1	220	-		0,858															
2362		2	-	0,867																	
2363		1	250	-		0,965															
2364		2	-	0,973																	
2365		1	280	-		1,057															
2366		2	-	1,065																	
2367		1	320	-		1,199															
2368		2	-	1,207																	
2369		1	360	-		1,341															
2370		2	-	1,349																	
2371		1	400	-		1,483															
2372		2	-	1,491																	
2373		1	450	-		1,661															
2374		2	-	1,669																	
2375		1	500	-		1,838															
2376		2	-	1,846																	
2377		1	560	-		2,052															
2378		2	-	2,060																	
2379		1	630	-		2,300															
2380		2	-	2,308																	
2381		1	710	-		2,513															
2382		2	-	2,521																	
2383		1	28	M30		140	30	28		44	-	19,0				80		40			1,011
2384		2				-					1,009										
2385		1			160	-			1,122												



Крепеж и метизы оптом с доставкой по России

[opm.ru](http://opm.ru)

(812) 335-00-52

(812) 600-40-71

(812) 320-28-84

e-mail: [spb@opm.ru](mailto:spb@opm.ru)

[msk.opm.ru](http://msk.opm.ru)

(495) 980-60-42

(495) 258-55-75

(916) 952-82-57

e-mail: [msk@opm.ru](mailto:msk@opm.ru)

2386		2						55				1,119
2387		1		180				-		100		1,215
2388		2						55				1,213
2389		1		200				-				1,326
2390		2						55				1,324
2391		1		220				-				1,382
2392		2						55				1,379
2393		1		250				-		125		1,585
2394		2						55				1,583
2395		1		280				-				1,752
2396		2						55				1,750
2397		1		320				-				1,807
2398		2						55				1,805
2399		1		360				-				2,195
2400		2						55				2,193
2401		1		400				-		140		2,407
2402		2						55				2,405
2403		1		450				-				2,677
2404		2						55				2,675
2405		1		500				-				2,962
2406		2						55				2,960
2407		1		560				-				3,295
2408		2						55				3,293
2409		1		630				-				3,683
2410		2						55				3,681
2411		1		710				-				4,066
2412		2						55				4,064
2413		1		800				-				4,626
2414		2						55				4,631
2415		1		900				-				5,181
2416		2						55				5,179
2417		1		1000				-				5,737
2418		2						55				5,734
2419		1	36	M42	200	42	36	54	24,0	125	50	2,544
2420		2						-				2,581
2421		1			220			65				2,761
2422		2						-				2,799
2423		1			250			65				3,088
2424		2						-				3,125
2425		1			280			65		140		3,391
2426		2						-				3,429
2427		1			320			65				3,826
2428		2						-				3,864
2429		1			360			65				4,261
2430		2						-				4,299
2431		1			400			65				4,697
2432		2						-				4,734
2433		1			450			65		160		5,210
2434		2						-				5,248
2435		1			500			65				5,764
2436		2						-				5,801
2437		1			560			65	25,0			6,407
2438		2						-				6,444
2439		1			630			65				7,168
2440		2						-				7,205
2441		1			710			65				8,038
2442		2						-				8,075
2443		1			800			65				10,974
2444		2						-				11,012
2445		1			900			65				12,062
2446		2						-				12,099
2447		1			1000			65				13,050
2448		2						-				13,087
2449		1			1250			65				13,767
7002-2450		2						-				13,805

Пример условного обозначения усиленного болта исполнения 1, размерами d=M16, L=80 мм:

*Болт 7002-2301 ГОСТ 12459-67*

(Измененная редакция, Изм. N 1, 2).



Крепеж и метизы оптом с доставкой по России

[opm.ru](http://opm.ru)

(812) 335-00-52

(812) 600-40-71

(812) 320-28-84

e-mail: [spb@opm.ru](mailto:spb@opm.ru)

[msk.opm.ru](http://msk.opm.ru)

(495) 980-60-42

(495) 258-55-75

(916) 952-82-57

e-mail: [msk@opm.ru](mailto:msk@opm.ru)

2. Материал - сталь марки 45 по ГОСТ 1050-88. Допускается замена на стали других марок с механическими свойствами не ниже, чем у стали марки 45.

(Измененная редакция, Изм. N 1).

3. Твердость головки - 36,5...41,5 HRC<sub>3</sub>.

(Измененная редакция, Изм. N 1, 2).

4. Неуказанные предельные отклонения размеров: H14, h14,  $\pm \frac{t_2}{2}$ .

(Измененная редакция, Изм. N 2).

5. Резьба метрическая - по ГОСТ 24705-81\*. Поле допуска резьбы - 6g по ГОСТ 16093-81\*\*.

\* На территории Российской Федерации действует ГОСТ 24705-2004;

\*\* На территории Российской Федерации действует ГОСТ 16093-2004. - Примечание изготовителя базы данных.

(Измененная редакция, Изм. N 1, 2).

6. Размеры сбегов и фасок для резьбы - по ГОСТ 10549-80.

(Измененная редакция, Изм. N 1).

7. (Исключен, Изм. N 1).

8. Покрытие - Хим. Окс. прм (обозначение покрытия - по ГОСТ 9.306-85).

(Измененная редакция, Изм. N 2).

9. Остальные технические требования - по ГОСТ 1759.0-87, ГОСТ 1759.1-82, ГОСТ 1759.2-82, ГОСТ 1759.4-87\*.

\* На территории Российской Федерации действует ГОСТ Р 52627-2006. - Примечание изготовителя базы данных.

10. Упаковка и маркировка - по ГОСТ 18160-72.

(Измененная редакция, Изм. N 1).



Крепеж и метизы оптом с доставкой по России

[opm.ru](http://opm.ru)

(812) 335-00-52

(812) 600-40-71

(812) 320-28-84

e-mail: [spb@opm.ru](mailto:spb@opm.ru)

[msk.opm.ru](http://msk.opm.ru)

(495) 980-60-42

(495) 258-55-75

(916) 952-82-57

e-mail: [msk@opm.ru](mailto:msk@opm.ru)